

HDMI / DVI / VGA over IP system

User Manual

Index

Features:	1
Application and Installation View:	2
Panel View:	4
Video Output Setting:	5
LED Indication Status:	5
RJ45 LED Indication Status:	5
Rotary Switch Function:	6
Panel Button Function:	6
Cable & Transmission Distance:	7
System Default Settings:	7
Bandwidth Chart:	7
USB Hot Key Function:	7
Remote Control Function:	8
Remote Control Button Function:	8
Remote Control Operation:	9
RS-232 Assign Mode:	11
Caution:	15
APP Control Function:	16
Web Setting Function:	17
Bonjour plug-in installation:	18
Login in to the web setting:	20
System Menu:	21
Channel expansion:	21
Network Menu:	23
Functions Menu:	24
Package:	26
Specification:	27

HDMI/DVI/VGA KVM & USB, RS232 , IR ,Analog Audio CAT5 Extender over IP

ITEM NO:



Transmitter:

HE05BT	HDMI & RS232 , IR, Unidirectional Analog Audio over IP
HKM01BT	HDMI KVM & USB, RS232 , IR, Bi-directional Analog Audio over IP
DKM01BT	DVI KVM & USB, RS232 , IR, Bi-directional Analog Audio over IP
VKM03BT	VGA KVM & USB, RS232 , IR, Bi-directional Analog Audio over IP

Receiver:

HE05BR	HDMI & RS232 , IR, Unidirectional Analog Audio over IP
HE05BER	HDMI & IR, Unidirectional Analog Audio over IP
HKM01BR	HDMI KVM & USB, RS232 , IR, Bi-directional Analog Audio over IP
VDKM01BR	VGA/DVI KVM & USB, RS232 , IR, Bi-directional Analog Audio over IP

HDV over IP series include HDMI, DVI, VGA KVM, USB with Analog audio, RS232, and IR CAT5 extender design for extends and distribute all signals over one CAT5 up to 150 meters, with local HD monitor output. It provides superior video quality up to 1920 x 1200 resolutions, and using cost effective Cat5e cable, instead of HDMI, DVI, and VGA, RS232 cables, for an easy, neater and reliable installation. The local and remote units can be connected together for a Point-to-Point connection via CAT5e/6 cable or a Point-to-Many connection via a managed network switch. Any combination of HDMI, DVI, and VGA transmitters and receivers can be used, easy to increase more sources or monitor for a flexible application. It is optimized for applications at streaming media, multimedia display and multi-data sharing, digital signage, home network integration, and industrial control, hospital, education, security, Matrix network system and system control over RS232 and equipment control over IR.

Features:

- I Extend and distribute HDMI/DVI/VGA signal with bi-directional RS232, USB signal, IR and analog audio signals over LAN.
- I Supports resolutions up to 1080p Full HD or 1920 x 1200 (WUXGA) 32bpp@ 60 Hz
- I Transmission range up to 150M over CAT5e, 180M over CAT6.
- I Support window based management software, using PC for easy setting input/output link.
- I Support Android/iOS APP control.
- I Receiver input source select could be from IR remote control or front panel button.
- I Built in RS232 distribution function, to send RS232 signal from one TX to multiple RX.
- I Supports 2-way RS232 commands at baud rate 115200 (control software on a PC, or other automated control system hardware) to control devices attached to the matrix using RS232. Full duplex data communication.
- I HDMI 1.3b and HDCP compliant.
- I HDMI audio support up to LPCM 7.1@192Khz
- I Built in Bi-Directional analog audio transmission (only in unicast mode).
- I Built in Bi-Directional IR extension.
- I HE05BT/HKM01BT/DKM01BT/VKM03BT transmitter unit built in HDMI/HDMI/DVI/VGA local loop output.
- I HKM01BR/VDKM01BR receiver unit with 4 ports USB devices (1 port USB 1.1 & 3 Port USB 2.0), to extend USB peripheral devices, such as flash disk, hard disk, keyboard, mouse, etc.
- I Use IGMP and Jumbo frame protocol Gigabit Switch Hub to do HD signal distribution and transmission.
- I Support point to point and multiple source devices to multi-display connections via Gigabit network switch
- I The system could be works with any combination on HDMI, DVI, VGA transmitters and receivers.
- I Support total of transmitter unit up to 100 pieces, receiver unit over 60000 pieces based on the number ports on your network switch.
- I Perfect for large scale remote HD content access and security monitoring systems, digital signage applications.
- I Optional model:
SR01: Signal repeater for longer distance application.

HDV Over IP Series :

ITEM NO.	Video Interface	Resolution	TX	RX	USB	RS232	IR Extender	Analog Audio	IR Control
HE05BT	HDMI	1080p	V			V	V	Unidirectional	
HKM01BT	HDMI	1080p	V		V	V	V	Bi-Directional	
DKM01BT	DVI	1920x1200	V		V	V	V	Bi-Directional	
VKM03BT	VGA	1920x1200	V		V	V	V	Bi-Directional	
HE05BER	HDMI	1080p		V				Unidirectional	V
HE05BR	HDMI	1080p		V		V	V	Unidirectional	V
HKM01BR	HDMI	1080p		V	V	V	V	Bi-Directional	V
VDKM01BR	VGA/DVI	1920x1200		V	V	V	V	Bi-Directional	V

Application and Installation View:

Point to Point Direct Connection: (Extender)



Point to Point With Switch Hub Connection: (Extender over LAN)



Multiple TX to Multiple RX via Switch Hub Connection

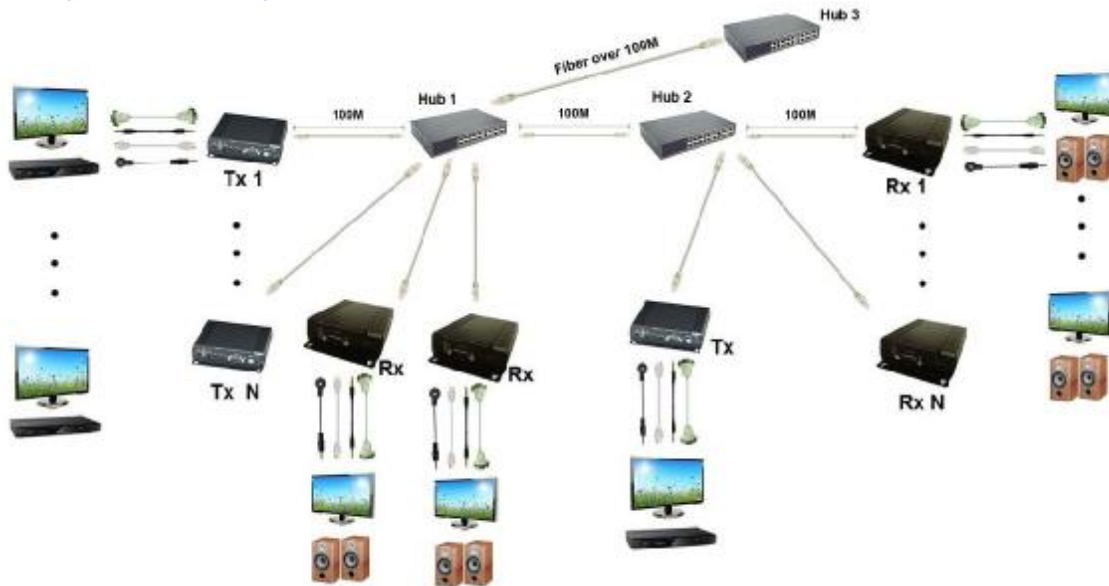

Multiple TX to Multiple RX Connection: (Matrix Switcher)

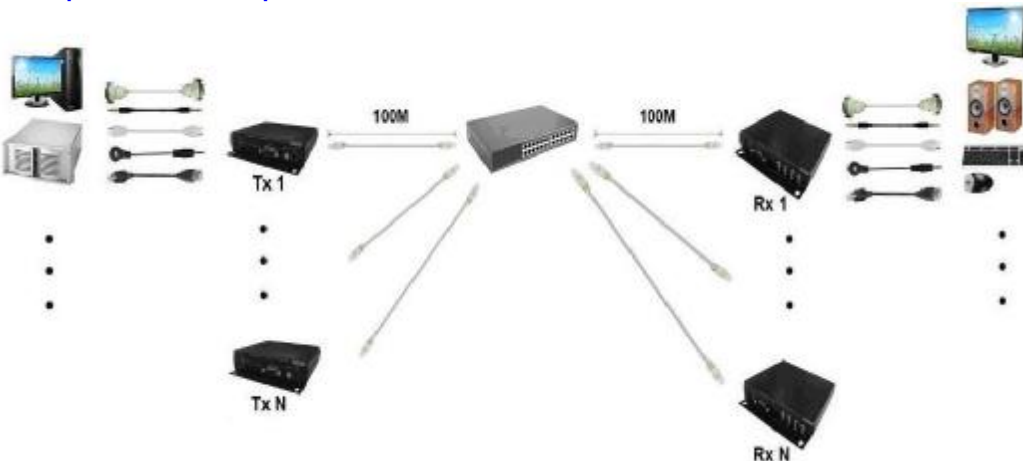

Multiple TX to One RX Connection: (KVM Switcher over IP)

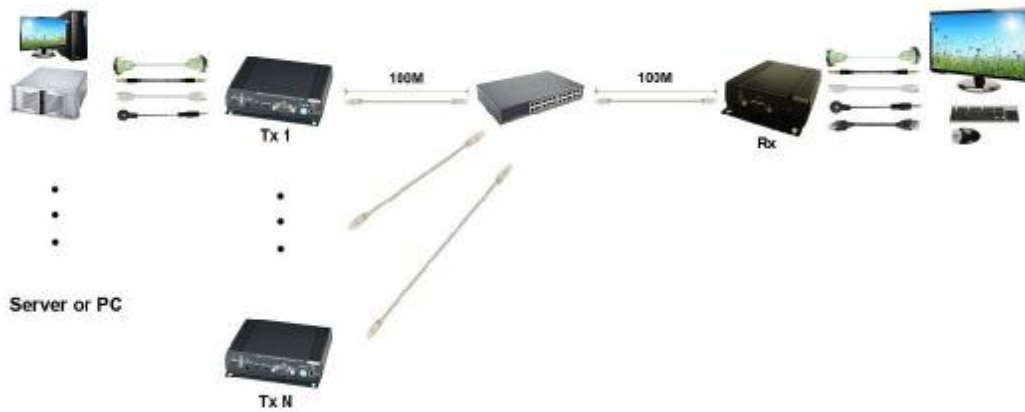

One TX to Multiple RX Connection: (Splitter)

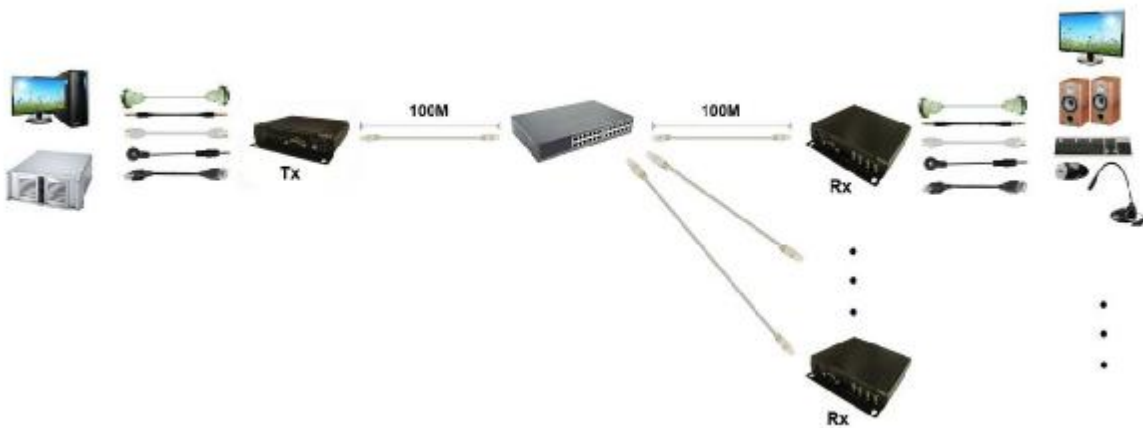

Optional Model: (order separately)

SR01 Signal Repeater

- I Extend data signal for an additional 120meters.
- I Application for HKM01B,DKM01B,VKM03B signals for extra long range transmission.
- I Ability to cascade connection with multiple SR01 for long range transmission
- I Built in LED status indication.
- I External power required.
- I Plug and play for easy installation.

Work with HDMI, DVI, VGA KVM over IP series:



Panel View:

Transmitters

HE05BT

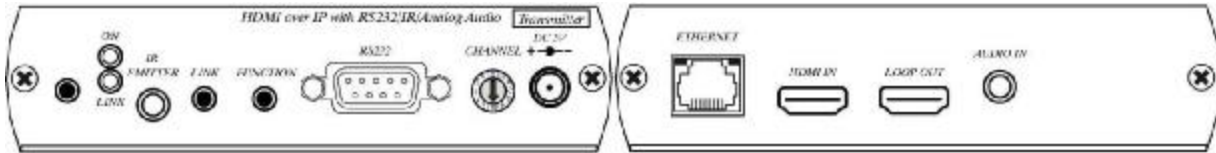

HKM01BT

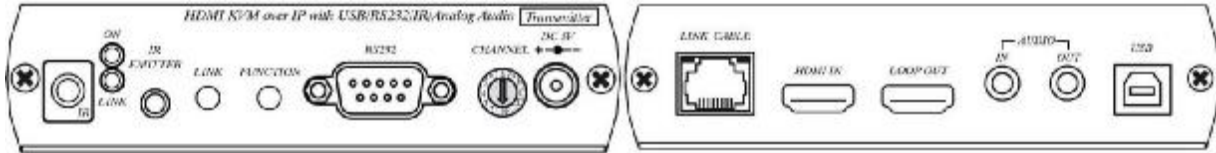

DKM01BT

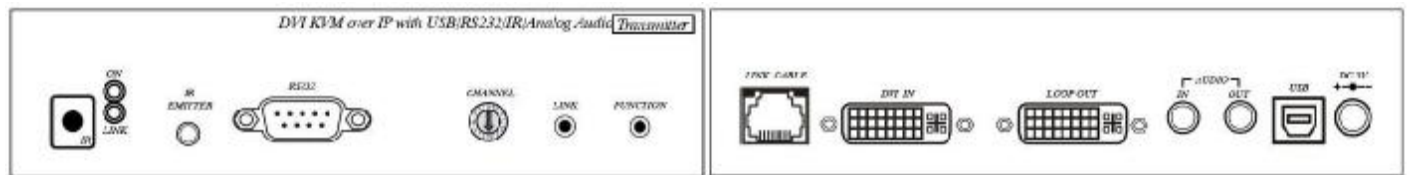

VKM03BT

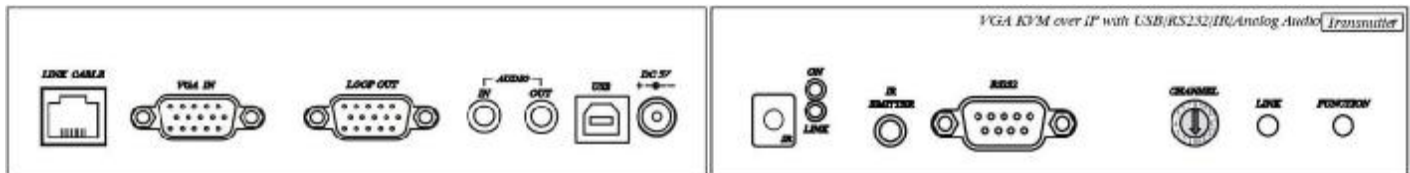

Receivers

HE05BER

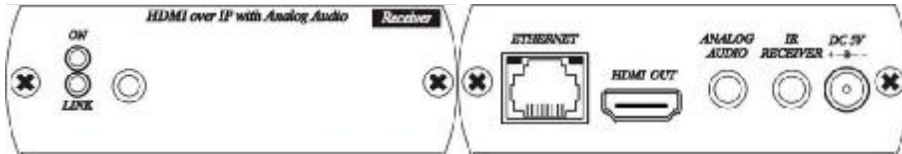

HE05BR

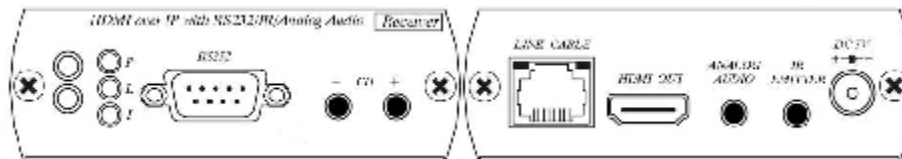

HKM01BR

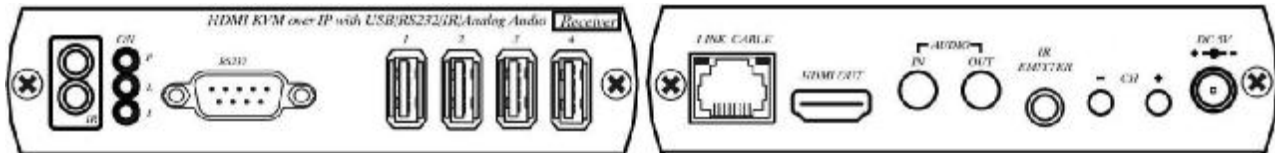

VDKM01BR

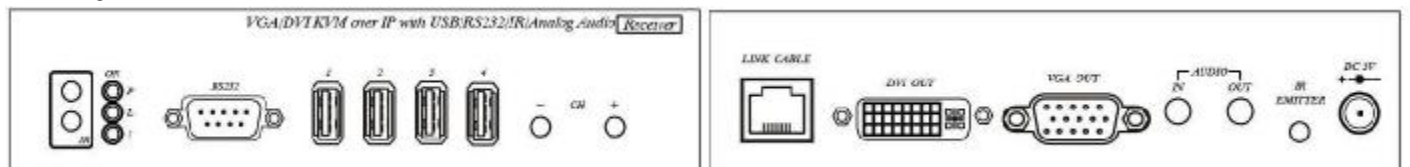

Video Output Setting:

VDKM01BR support both DVI and VGA dual output, default is DVI output only.

You could either change the output setting before power on or in using as follows:

1. To change the output setting **before power on**, please press and hold below buttons and then plug the power, release the button **after 1 or more seconds** (about 30 seconds to boot).

[CH-]: VGA output only

[CH+]: DVI output only

Notice: support single output only.

2. To change the output setting **in using**, please press below buttons for **5 seconds** till power LED flash, it will reboot automatically (about 30 seconds to reboot).

[CH-]: VGA output only

[CH+]: DVI output only

[CH-] and [CH+]: DVI and VGA dual output

Notice: in dual output mode the DVI monitor must be connected and power on.

LED Indication Status:

Panel LED	Status	Description
Power Green LED	Off	No power
	On	Boot completed
	Flash Twice	Booting
	Flash Slowly	Turn off video output (Not available for transmitters & HE05BER)
	Pulse	Screen saver mode (Not available for transmitters & HE05BER)
Link Blue LED	Off	Not cconnected with transmitter/receiver
	On	Connected & video is streaming
	Flash	Connecting, or no source input from transmitter
IR Red LED	Off	No IR signal transmitting /receiving (not available for transmitters & HE05BER)
	On	Transmitting /receiving IR signal (not available for transmitters & HE05BER)

RJ45 LED Indication Status:

RJ45 LED	Status	Description
Orange LED	Off	Ethernet not connect
	On	Ethernet connected
Green LED	Off	No data transmission
	Flash	Data transmission

Rotary Switch Function:



Transmitter and receiver must setting at same channel in order to do mutual transmission.

Rotary switch to be follow 16 HEX, could switch “ 0 ~ F “ total 16 channels, A = channel 10, B = channel 11, others channel same as 16 hex conversion.

Transmitter channel setting must be unique to avoid conflict with any other transmitters.

After rotary switch change must reboot or power off/on the transmitter

Please refer Web Setting page to set transmitter by APP or web for over 16 channels

Panel Button Function:

ITEM	TRANSMITTER	
Button	LINK	FUNCTION
Short Press	Remote output (on / off)	Video Mode / Graphic Mode
Long Press (3 seconds)	Loop output (on / off)	Anti-Dither (1/2/ off)
Press to power on (Hold until Green LED Flash)	N/A	Update EDID from loop output
Press to power on (Hold until Green and Blue LED Flash then manually reboot)	RESET to Default	N/A

Above “**bold font**” part as the default

ITEM	RECEIVER	
Button	CH. -	CH. +
Press both	Confirm / Enter menu / Turn on video output	
Short Press	Reduce the numbers of Channel/Menu/Value	Increase the numbers of Channel/Menu/Value
Press for 1 second before power on, or press for 5 seconds in using (VDKM01BR only)	VGA output only	DVI output only
Press both for 5 seconds (VDKM01BR only)	DVI and VGA output both (DVI monitor must be connected and power on)	

Above “**bold font**” part as the default

For HE05BER please use IR remote control or APP/PC Software for channel setting.

RJ45 pin define:

Link Cable (TIA/EIA-568-B)

1. Orange-white Data 1 +

2. Orange Data 1 -

3. Green-white Data 2 +

4. Blue Data 3 +

5. Blue-white Data 3 -

6. Green Data 2 -

7. Brown-white Data 4 +

8. Brown Data 4 -

Cable & Transmission Distance:

Link Cable use high quality Cat.5e UTP/STP/FTP or Cat.6 UTP cable

Transmission distance will be affected by equipment (Switch HUB), cable quality...etc.

When using CAT.5e cable connect transmitter and receiver directly without Ethernet switch, the maximum transmission distance up to 150M, using CAT.6 cable up to 180M.

You can also use model no: SR01 repeater for extended longer distance or using Gigabit Switch hub which support **IGMP** protocol and **Jumbo Frame 8K** for signal distribution or extend distance.

System Default Settings:

Transmitter / receiver support **Unicast** and **Multicast** two mode, default is Multicast.

In Multicast mode it could be one to one, one to multi, multi to on or multi to multi applications.

The analog audio output of transmitter and input of receiver will be off in this mode, analog audio only from transmitters send to receivers.

Unicast mode suitable for one to one or multiple transmitters to one receiver applications.

Analog audio bi-direction transmission only in **Unicast** mode, please refer to the web setting chapter: Casting Mode

System default IP setting is **Auto IP**, it will assign **169.254.X.X** (submask **255.255.0.0**) to transmitters and receivers, you could also set to DHCP or Static IP, please refer to web setting chapter: IP Setup.

Bandwidth Chart:

The bandwidth will be varied based on different resolution. Higher resolution may not request bigger bandwidth. Below Chart is the resolution and bandwidth status for reference.

Resolution (@60Hz)	Average Bandwidth (Mbps)	Resolution (@60Hz)	Average Bandwidth (Mbps)
1080p	77 (24 ~ 91)	1600x1200 (UXGA)	59 (24 ~ 73)
720p	46 (29 ~ 150)	1280x1024 (SXGA)	58 (31 ~ 76)
480p	63 (36 ~ 73)	1024x768 (XGA)	118 (56 ~ 138)
		800x600 (SVGA)	83 (64 ~ 107)

Above bandwidth chart not include USB transmission, it cost up to 50 Mbps when transferring mass data.

System support 16 full HD video source transmitted simultaneously, for more than 16 video sources can be set through web page or APP.

System scalability is limited only by uplink and stacking connector bandwidths, for example under Gigabit Ethernet network, the total flow must not exceed 1000Mbps to avoid any delay on video streaming. If the video play with 1080p resolution, the transmitter allow maximum up to 10pcs for simultaneous video streaming.

For 11~20 sources: use switches which support 802.3ad Link Aggregation or smart (or intelligent) switches to get 2 Gbps or more bandwidth.

For 21~100 sources: use switches which support SFP+ uplink or stackable switches to get 10 Gbps bandwidth.

USB Hot Key Function: (Not available for HE05BT/HE05BR/HE05BER)

In multicast mode support multi USB keyboard and mouse in each receivers, just plug and play, but only one USB FLASH drive / hard disk could be used at same time.



You have to click "Pause/Break" key three times of the keyboard on the receiver to establish USB FLASH drive /hard disk connection.

Remote Control Function:























If you do not use PC computer management to setup receiver, then you could use the IR infrared remote control to preset channel selection. Using the IR remote control to the front of receiver will be ok.

Initial at first time use the remote control or after change battery of remote control, the IR remote control and the equipment Remote ID must be using same ID. The default Remote ID is 8.

To setting the Remote ID, Press and hold power button, then press button 8 to complete the setting.  +  .(for example)

Remote Control Button Function:

Symbol	Function
	Power Temporarily turn off/on the video output /Setup remote control Remote ID
	MENU Menu selection, input numbers after press menu button
	LEFT Previous channel
	RIGHT Next channel
	UP Previous quick Menu selection
	DOWN Next quick Menu selection
	ENTER Confirmation / display the current channel
	1 Number 1
	2 Number 2
	3 Number 3
	4 Number 4
	5 Number 5
	6 Number 6
	7 Number 7
	8 Number 8
	9 Number 9
	0 Number 0
	* Cancel / exit
	# Clear input number
	A Favorite channel switching
	B Back to previous channel

Remote Control Operation:

Select Channel:

Mode 1: use **t** or **u** select channel and wait 3 seconds, or press **ENTER** immediately to confirm.

Mode 2: enter the channel number and press **ENTER** to confirm the input channel.

Select Function:

Mode 1: use **p** or **q** select function, press **ENTER** to confirm.

Mode 2: press **ENTER**, then input function number as below, press **ENTER** to confirm.

Basic Menu Number:

A	Add Favorite Channels	Add current channel to favorite channel list (Max. 28 ch.)
B	Remove Favorite Channels	Remove current channel from favorite channel list
0	MAC Address	Display MAC Address of receiver
1	IP Address	Display IP Address of receiver
2	Host IP Address	Display IP Address of current connected transmitter
5	System Version	Show system version information
6	Restart Link	Reconnect with transmitter
7	Stop Link	Stop the connection with transmitter
8	Display Advanced Menu	Display advance menu
9	Hide Advanced Menu	Hide advance menu

Advance Menu Number:

10	Enable Screensaver Mode	No video input for one minute later, video output turn off
11	Disable Screensaver Mode	Disable screen saver mode
12	Enable Channel Expansion	Enable channel expansion (CH.0 ~ CH.99)
13	Disable Channel Expansion	Disable channel expansion (CH.0 ~ CH.15)
14	Device No	Show device number
15	Set Device No	Set device number to 0~9999 (default 0)
16	Group No	Show group number
17	Set Group No	Set group number to 0~99 (default 0)
18	Party No	Show party number
19	Set Party No	Set party number to 0~99 (default 0)
20	Remote ID	Show current Remote ID setting
21	Set Remote ID	Set Remote ID to 0~9 (default 8)
22	Enable IR Remote	Enable IR Remote
23	Disable IR Remote	Disable IR Remote
24	Enable IR Extender	Enable IR Extender
25	Disable IR Extender	Disable IR Extender
26	Enable Channel Button	Enable Channel Button
27	Disable Channel Button	Disable Channel Button
28	Enable RS-232 Assign Mode	Enable RS-232 Assign Mode, auto reboot after setting
29	Disable RS-232 Assign Mode	Disable RS-232 Assign Mode, auto reboot after setting
30	Video or Graphic Mode	Switch Host Video (default) or Graphic Mode
31	Anti-Dithering	Switch Host Video Anti-Dithering define (default is off)
32	Enable Direct Access Menu	Accept direct input function number of advance menu
33	Disable Direct Access Menu	Advance menu must be enabled to execute function
34	Enable Fast Switch	Keep screen then switch channel (around 2 sec.)
35	Disable Fast Switch	Blank screen then switch channel (around 5~7 sec.)
36	Power Button Mode 0	Keep stream when turn off monitor by IR power button
37	Power Button Mode 1	Stop stream when turn off monitor by IR power button
40	Enable Hide Menu 8 & 9	Hide Menu function 8 and 9
41,	Disable Hide Menu 8 & 9	Display Menu function 8 and 9
70	Favorites List	Show favorites channels list
71	Sort Favorite Channel	Sort Favorite Channel
72	Enable Only Favorite	Only favorite channel can be switched
73	Disable Only Favorite	All channel can be switched
74	Enable Lock Favorite	Lock Favorite Channel list and not able to add/remove
75	Disable Lock Favorite	Favorite Channel list could be add/remove
76	Enable Auto Sort Favorite	Sort Favorite Channel list automatically
77	Disable Auto Sort Favorite	Favorite Channel list not sort

80	System Information	Casting mode, version information, continuous uptime
81	Network Information	Status of link, MAC, IP, Host IP address
82	Channel Information	Current/last channel, expansion, compatibility
83	Device No Information	Show device, group, party number
84	IR & Button Information	Status of IR remove ID, IR remote, IR extender, button
85	RS-232 Assign Information	Status of RS-232 assign mode, channel, IP, token timeout
86	Communication Information	Status of RS-232 control command setting

System Maintains Menu Number: (not display in OSD menu)

300	Force Update EDID of a Target Client	Set host EDID from current monitor
301	Starting USB	Redetect and connect USB device (USB mode only)
310	VGA Mode	Set output to VGA mode (VDKM01BR only)
311	DVI Mode	Set output to DVI mode (VDKM01BR only)
312	DVI + VGA Mode	Set output to DVI + VGA mode (VDKM01BR only)
333	Reset to Factory Default	Reset to Factory Default
400	<u>Enable Diagnostic Information</u>	Enable bottom diagnostic information of screen
401	Disable Diagnostic Information	Disable bottom diagnostic information of screen
402	Enable Channel Compatibility	Enable channel compatibility with third party
403	<u>Disable Channel Compatibility</u>	Disable channel compatibility with third party
404	Enable Fatal Error Reboot	Enable auto reboot when fatal error found
405	<u>Disable Fatal Error Reboot</u>	Disable auto reboot when fatal error found
410	<u>Enable Keep RS232 Connection</u>	Enable keep RS232 connection at assign mode
411	Disable Keep RS232 Connection	Disable keep RS232 connection at assign mode
420	Input Analog In Volume	Set volume 0~100 for analog in (firmware A6.3.0 up)
420	Input Analog Out Volume	Set volume 0~100 for analog out (firmware A6.3.0 up)
430	Newline = Unix (CR)	Set RS-232 command Newline to Unix mode
431	Newline = Windows (CR+LF)	Set RS-232 command Newline to Windows mode
432	Newline = Mac (LF)	Set RS-232 command Newline to Mac mode
433	Newline = Other (LF+CR)	Set RS-232 command Newline to others mode
434	Capture Char = 0x0A (LF)	Set RS-232 command end characters
435	Capture Char = 0x0D (CR)	Set RS-232 command end characters
436	Command = Case Sensitive	RS-232 command case sensitive
437	Command = Case Insensitive	RS-232 command case insensitive
438	Command = Disable	Turn off RS-232 command control function
440	Display Settings Value	Display internal settings value
441	Input Settings Value	Input internal settings value
999	Reboot	Restart the system

*Gray shading means not available for HE05BER

****Function with bold and underscore is factory default**

***Press any key of IR remote or panel button to exit screen saver mode

****Press **POWER** of IR remote or panel button CH- and CH+ together to turn on video output

*****Fast Switch mode works best when: resolution, frame rate, scan mode (interlaced/non-interlaced), color depth, color space, interface (HDMI/DVI), HDCP mode (ON/OFF) all above are the same.

RS-232 Assign Mode:
(Not available for HE05BER)

System default setting of RS-232 is extender mode, the connection topology same as the channel ID. RS232 ports of receivers only connect to the transmitter with same channel ID as below diagram. This mode suitable for direct RS232 transmission between Tx and Rx.

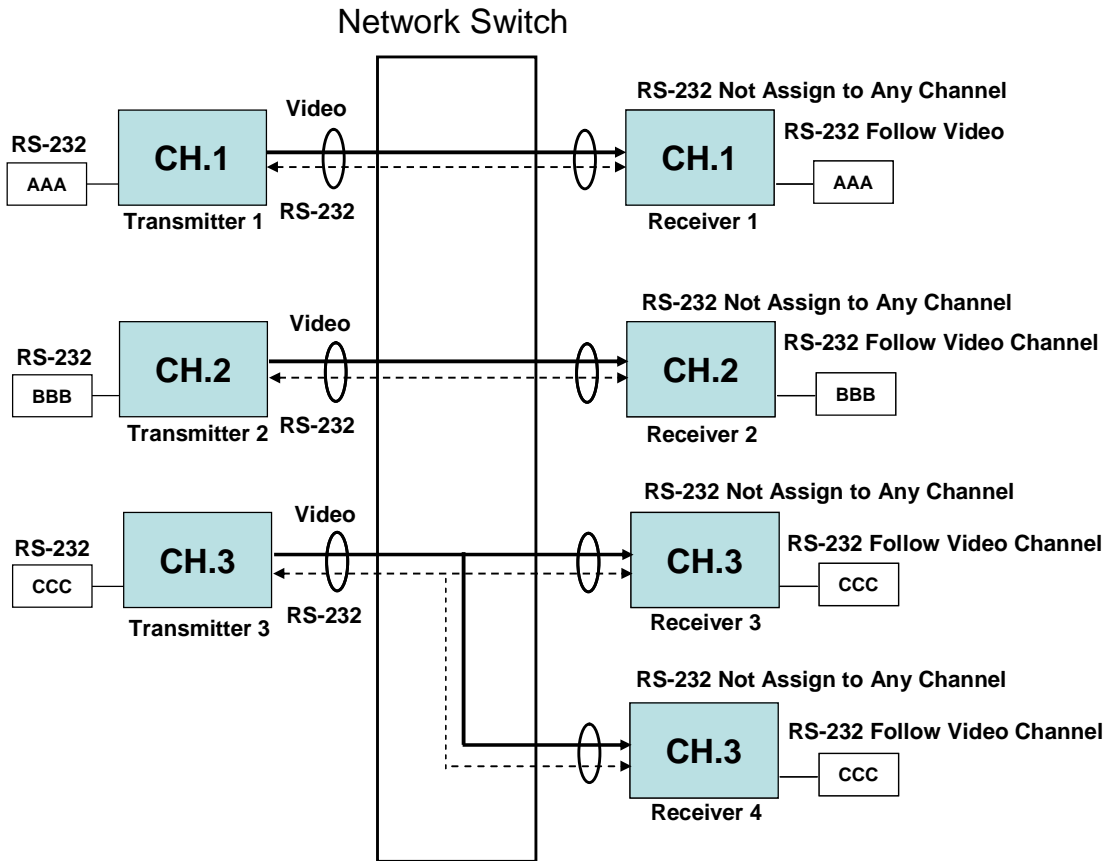

For RS232 automation control you could enable RS232 assign mode to fix the connection of RS232 not follow channel ID as below diagram. (Receiver 1~3 fix to channel 1 by assign mode, receiver 4 follow the channel ID without assign mode)

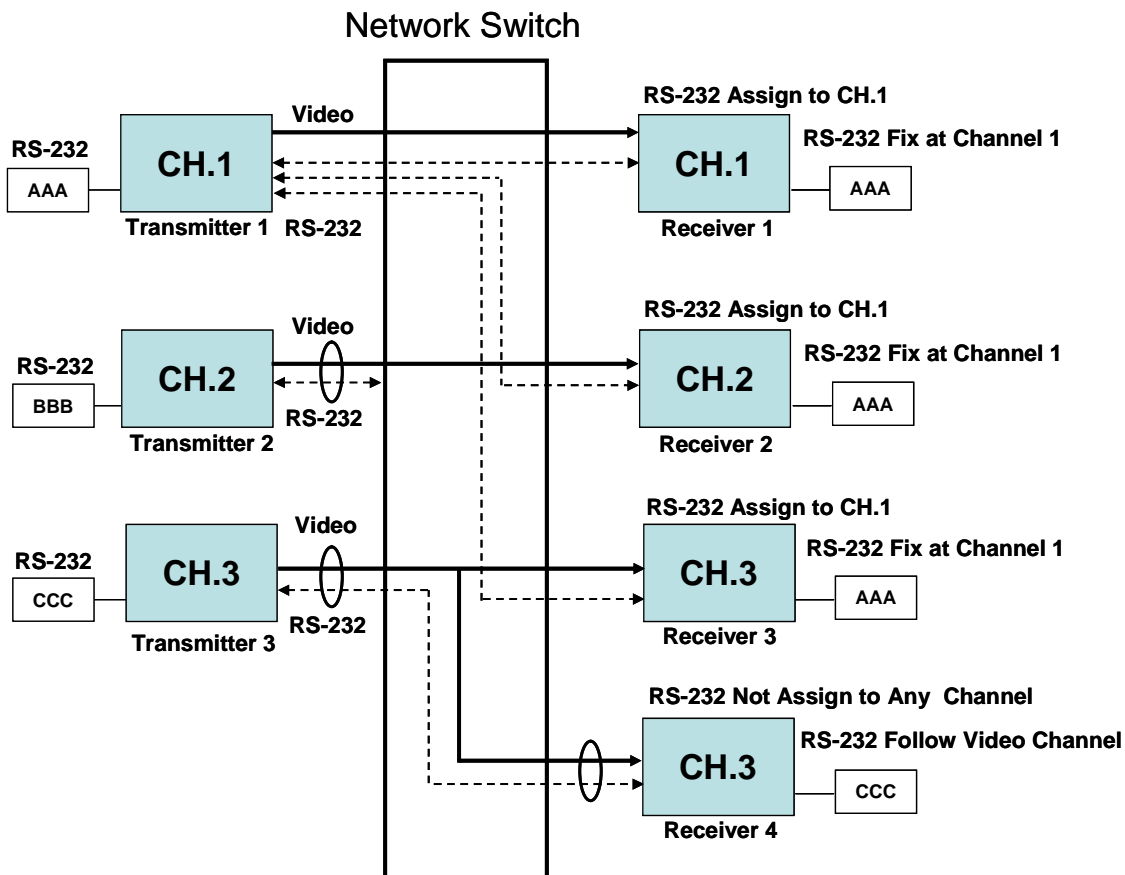

After the receivers and transmitter you want to keep RS232 connection established then press IR remote button **MENU, 2, 8, ENTER** to enable RS232 assign mode.

★ If you switch to a not available channel the RS232 connection will be cut and lose control, the RX will switch back to assigned channel after 3 seconds automatically to keep RS232 connection

★ If IP address of transmitter has been changed you have to enable RS232 assign mode for recovers again.

To disable RS232 assign mode press IR remote button **MENU, 2, 9, ENTER**

RS-232 Control command : (Not available for HE05BER)

User could use RS-232 port of transmitters to operate/setup the receivers at same channel by program like Hyper Terminal which built-in Windows XP and before version.

Hyper Terminal setting: [**115200 bps (8-N-1), Flow control: None**] (Properties -> Settings -> ASCII Setup... and select **“Send line ends with line feeds” & “Echo typed characters locally”**)

★**We recommend enable RS232 assign mode for all receivers when you use RS232 command to control them, and set all receivers assign to only one transmitter to avoid RS232 connection broken by video channel switching.**

Command format: >CMD_Address> Command Parameters

Address, command and parameters are char, not hex code

Enter (LF or CR+LF) is required to execute the command

All accord receivers will run the command and parameters, we also add 3 kinds of user defined numbers except MAC & IP (Device No · Group No · Party No) for flexible application:

Mxxxx	The last 4 digits of MAC Address of receiver	e.g.: 221868860123 = M0123
Ixxxx	The last 2 column of IP Address (HEX) of receiver	e.g.: 169.254.012.034 = I0C22
Dxxxx	Device No	e.g.: Device No 1234 = D1234
Gxx	Group No	e.g.: Group No 12 = G12
Pxx	Party No	e.g.: Party No 34 = P34
Cxx	Channel No	e.g.: Channel 12 = C12
ALL	All receivers	

Response format: <ACK_Address< Response character

Receivers will response message to transmitter as above format and send CR+LF after response

When send command to multiple receivers they will not response by default.

To enforce response function please add “!” in front of the commands and receivers will respond in sequence regarding device number X 15ms (0ms, 15ms, 30ms and so on), so we recommend set Device No for all receivers if you need response from multiple receivers.

To prevent respond conflict or long time waiting by mass receivers, we do not recommend use “!” with Gxx, Pxx, Cxx, and ALL

Command and Parameters List:

Command	Function	Parameters	Response
CHANNEL	Select Channel	0 ~ 99 (Channel No.) ? (display setting)	OK = Setting successful ERROR = Setting fail
REMOTE_ID	Set Remote ID	0-9 (Remote ID No.) ? (display Remote ID No.)	OK = Setting successful ERROR = Setting fail
BUTTON	Set button	Enable / Disable / ? (display setting)	OK = Setting successful ERROR = Setting fail
IR_REMOTE	Set IR remote	Enable / Disable / ? (display setting)	OK = Setting successful ERROR = Setting fail
IR_EXTENDER	Set IR Extender	Enable / Disable / ? (display setting)	OK = Setting successful ERROR = Setting fail
SCREENSAVER	Screen Saver	Enable / Disable / ? (display setting)	OK = Setting successful ERROR = Setting fail
CH_EXPANSION	Channel expansion	Enable / Disable / ? (display setting)	OK = Setting successful ERROR = Setting fail
DEVICE	Set Device Number	0 ~ 9999 (Device No.) ? (display setting)	OK = Setting successful ERROR = Setting fail
GROUP	Set Group Number	0 ~ 99 (Group No.) ? (display setting)	OK = Setting successful ERROR = Setting fail
PARTY	Set Party Number	0 ~ 99 (Party No.) ? (display setting)	OK = Setting successful ERROR = Setting fail
OSD_ON	Display character on screen 30 seconds	Character (alphabet and numbers)	OK = Setting successful ERROR = Setting fail
OSD_OFF	Turn off the OSD	N/A (turn off immediately) 0~655 (Delay time, based on 100ms) ? (display time left)	OK = Setting successful ERROR = Setting fail
SCREEN	Turn on/off screen	ON / OFF ? (display setting)	OK = Setting successful ERROR = Setting fail
RS232_ASSIGN	Set RS232 assign mode	ON / OFF ? (display setting)	OK = Setting successful ERROR = Setting fail
FAVORITE_ADD	Add channel to favorite list	N/A (display setting) 0~99 (channel number) ? (display available space)	OK = Setting successful ERROR = Setting fail
FAVORITE_DEL	Delete channel from favorite list	N/A (display setting) 0~99 (channel number)	OK = Setting successful ERROR = Setting fail
FAVORITE_CLR	Clear favorite list	N/A	OK = Setting successful ERROR = Setting fail
FAVORITE_ONLY	Only favorite list can be select	ON / OFF ? (display setting)	OK = Setting successful ERROR = Setting fail
QUERY_MAC	Query MAC address	N/A	MAC address
QUERY_IP	Query IP address	N/A	IP address
RESOLUTION	Query source resolution	N/A	Resolution information of source
SAVE	Save RS232 settings	N/A	OK = Save successful ERROR = Save fail
REBOOT	System reboot	N/A	SYSTEM REBOOT

※ The maximum of OSD_ON is 30 characters, not support comma sign「,」, colon「:」 and double quotation marks 「”」, some characters must use \x## format to display, ## means the characters number in ASCII HEX code

e.g.: \x0a is line feed, \x28 is (brackets sign, \x22 is “ sign

Example:

>CMD_M1234> CHANNEL 12 (Set receiver which last 4 digits MAC Address is 1234 to Channel 12)
(HEX code: 3E 43 4D 44 5F 4D 31 32 33 34 3E 20 43 48 41 4E 4E 45 4C 20 31 32 0D 0A)

<ACK_M1234< OK (Receiver which last 4 digits MAC Address is 1234 response “OK”)
(HEX code: 3C 41 43 4B 5F 4D 31 32 33 34 3C 20 4F 4B 0D 0A)

>CMD_I0A12> CHANNEL 3 (Set receiver which IP Address is 169.254.10.18 to Channel 3)
(HEX code: 3E 43 4D 44 5F 49 30 41 31 32 3E 20 43 48 41 4E 4E 45 4C 20 33 0D 0A)

<ACK_I0A12< OK (Receiver which IP Address is 169.254.10.18 response “OK”)
(HEX code: 3C 41 43 4B 5F 49 30 41 31 32 3C 20 4F 4B 0D 0A)

>CMD_G34> CHANNEL 5 (Set receivers which Group No is 34 to Channel 5)

(HEX code: 3E 43 4D 44 5F 47 33 34 3E 20 43 48 41 4E 4E 45 4C 20 35 0D 0A)

(No response from multiple receivers)

>CMD_ALL> !OSD_ON Hello! \x28123\x29 \x22ABC\x22 (Show 「Hello! (123) “ABC”」 to all monitor and send response)

(HEX code: 3E 43 4D 44 5F 41 4C 4C 3E 20 21 4F 53 44 5F 4F 4E 20 48 65 6C 6F 21 20 5C 78 32 38 31 32 33 5C 78 32 39 20 5C 78 32 32 41 42 43 5C 78 32 32 0D 0A)

<ACK_M0219< OK (Receiver which last 4 digits MAC Address is 0129 response OK)
(HEX code: 3C 41 43 4B 5F 4D 30 32 31 39 3C 20 4F 4B 0D 0A)

<ACK_M021B< OK (Receiver which last 4 digits MAC Address is 021B response OK)
(HEX code: 3C 41 43 4B 5F 4D 30 32 31 42 3C 20 4F 4B 0D 0A)

<ACK_M021C< OK (Receiver which last 4 digits MAC Address is 021C response OK)
(HEX code: 3C 41 43 4B 5F 4D 30 32 31 43 3C 20 4F 4B 0D 0A)

>CMD_ALL> OSD_OFF 10000 (All receiver turn off OSD after 10 seconds)

(HEX code: 3E 43 4D 44 5F 41 4C 4C 3E 20 4F 53 44 5F 4F 46 46 20 31 30 30 30 0D 0A)

Caution:

1. Transmitter/receiver boot time require 30 seconds
2. Transmitter must be reboot to apply channel setting by hardware rotating switch
3. Not recommend to work with existing LAN connection to avoid large video, data transmission or multicast packets to slow down your other LAN devices.
4. Gigabit switching hub must support IGMP and Jumbo Frame over 8K in order to achieve the best quality
5. If monitor shows green screen, please check if the switch running under gigabit and IGMP/Jumbo Frame function enabled.
6. If video not smooth please check if IGMP function enabled or bandwidth of switch closes to maximum.
7. When using computer or mobile APP management the IP address should be set in same network segment.
8. Computer software and APP operation please refer to software operating instruction.
9. If receiver switch to transmitter which no video input, it will show blank screen or last still image for a while.
10. Fast switch mode might cause screen or audio abnormal briefly when switch channel.
11. In high resolution (like 1080p) the OSD response will be delayed a little bit.
12. If IR remote not work properly, please check the battery (especial in low temperature) and reset IR ID.
13. Audio in of HKM01BR, VDKM01BR is designed for Mic in, not for Line in
14. Screen saver function not support monitors which only works based on HDMI +5V signal.
15. If any video resolution issue please try to reset EDID of TX by web or use MENU 300 to copy EDID from the monitor of RX

APP Control Function:

APP name: Remote Control Center (Basic control as IR remote for end user)



Google Play Download Link

<https://play.google.com/store/apps/details?id=sct.com.remotecontrolcenter>

iTunes Download Link

<https://itunes.apple.com/us/app/remote-control-center/id929873260?l=zh&ls=1&mt=8>

Google Play Download QR code



iTunes Download QR code



APP name: Remote Control Center PRO (Advanced control for installer)



Google Play Download Link

<https://play.google.com/store/apps/details?id=sct.com.remotecontrolcenterpro>

iTunes Download Link

<https://itunes.apple.com/us/app/remove-control-center-pro/id930779117?l=zh&ls=1&mt=8>

Google Play Download QR code



iTunes Download QR code



For APP instruction please refer attached software CD
To avoid confusion we do not recommend install multiple APP in one device

Web Setting Function:

System provide detail settings over web browser, you could input the IP address of transmitter / receiver at link column of browser if you know the exact IP address of them.

There are four ways to get the IP address of receiver:

1. Connect monitor with receiver, **local IP** shows on right bottom screen when receiver booting or transmitter not connected(or no video input)
2. Press remote control button **MENU, 1, ENTER** (IP Address), it will shows the receiver IP Address on screen
3. Install Internet explorer plug-in: Bonjour , click device name to enter web setting page to get the IP address(please refer Bonjour plug-in installation)
4. Run "Device Manager" program in CD, enter the Client page(please refer software instruction)

There are four ways to get the IP address of transmitter:

1. Connect monitor with receiver, connect receiver with transmitter and set in the same channel, **remote IP** shows on right bottom screen when receiver booting or no video input from transmitter
2. Connect monitor with receiver, connect receiver with transmitter and set in the same channel, press remote control button **MENU, 2, ENTER** (Host IP Address) at receiver side, it will shows the transmitter IP Address on screen(must remove the HDMI cable of transmitter or turn off the video source).
3. Install Internet explorer plug-in: Bonjour , click device name to enter web setting page to get the IP address(please refer Bonjour plug-in installation)
4. Run "Device Manager" program in CD, enter the Host page(please refer software instruction)

System default IP setting is Auto IP, it will assign 169.254.X.X (subnet mask 255.255.0.0) to transmitters and receivers, you could also set to DHCP or Static IP.

You computer must set in same subnet mask to enter the web setup page.

If you do not sure the IP address of transmitters/receivers you could reset the transmitters and receiver to default.

For transmitters: press the LINK button to power on (Press and hold until Green and Blue LED Flash) to reset to default.

For receivers: press remote control **MENU, 3, 3, 3, ENTER** to reset to default.

Bonjour plug-in installation:

- a. Click "BonjourSDKSetup.exe" to install Bonjour plug-in for Internet Explorer.



- b. Click "Next" to continue.



- c. Click "I accept the terms in the license agreement" to continue.

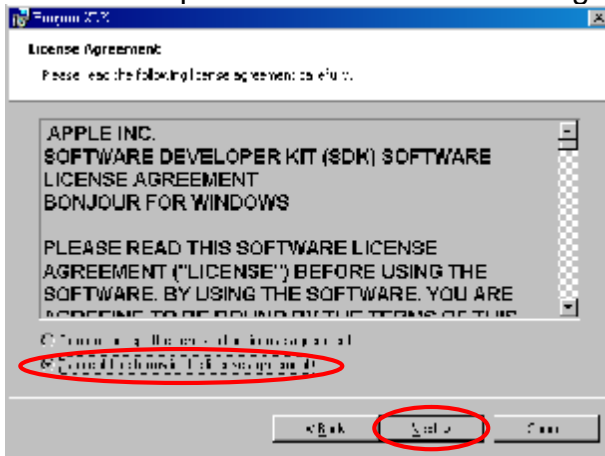

- d. Click "Next" to continue.

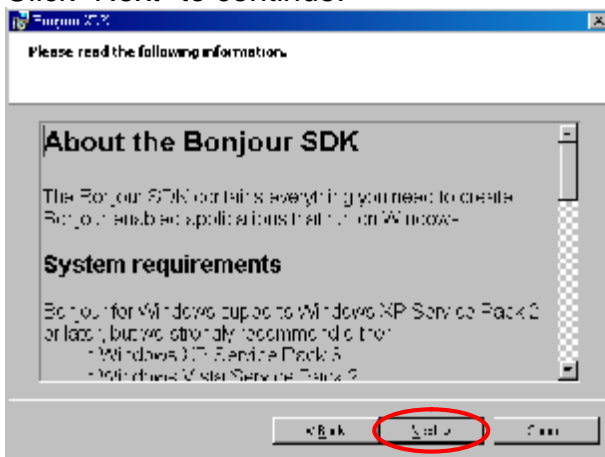

e. Click "Install" to start installation.

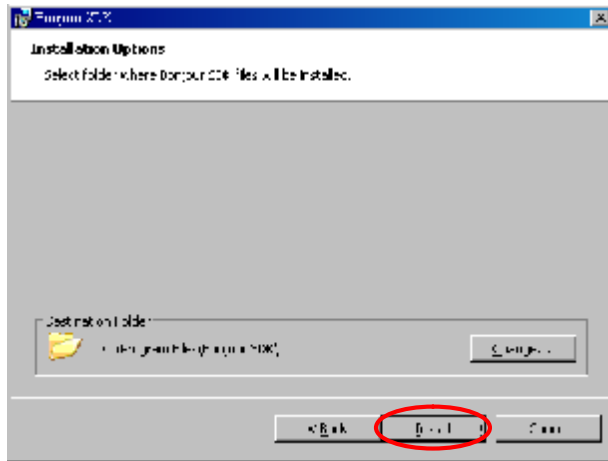

f. Click "Finish" to exit installation.

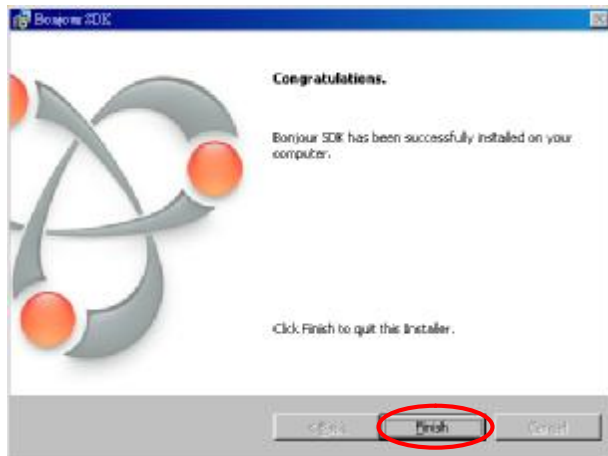

g. Right click on "My Network Place" à "Properties" then right click on "Local Area Connection" à "Properties" then double click on "Internet Protocol (TCP/IP)" to setting as below:
(IP address **169.254.111.111**, sub mask **255.255.0.0**)

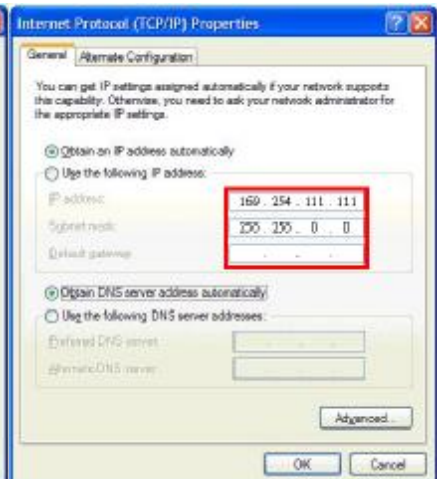
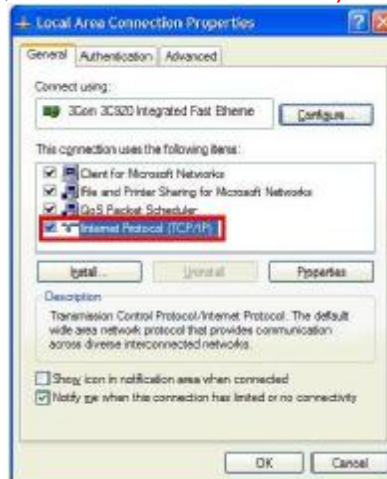

Login in to the web setting:

Use CAT5 cable to connect transmitter/receiver RJ45 port to PC LAN port, direct input known IP address of TX/RX, or open IE browser then select View à Explorer Bars à Bonjour.

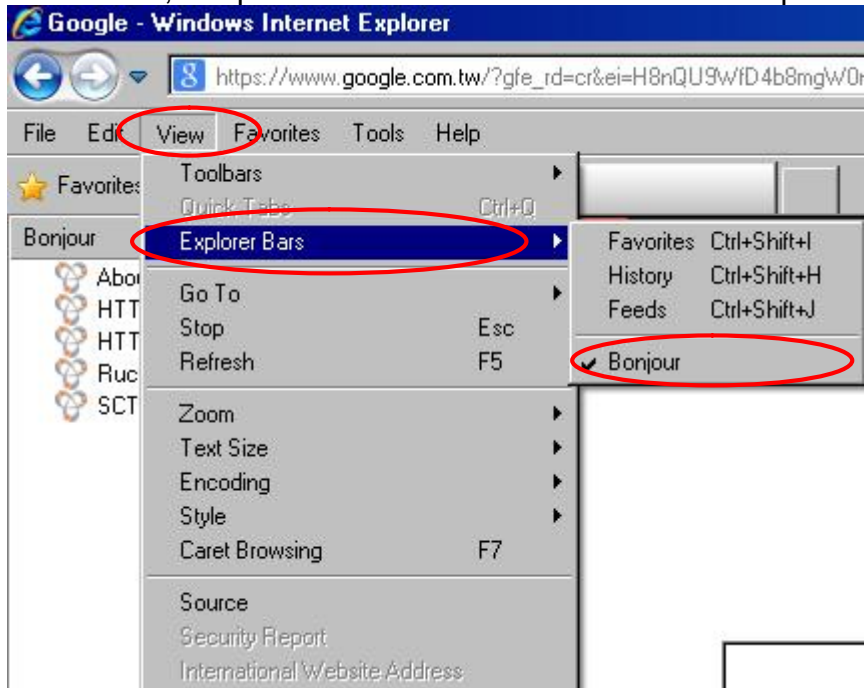

Double click on “HTTP on ast2-gateway(transmitter)” or “HTTP on ast2-client (receiver)”, it will pop up web setup in Bonjour windows as below:

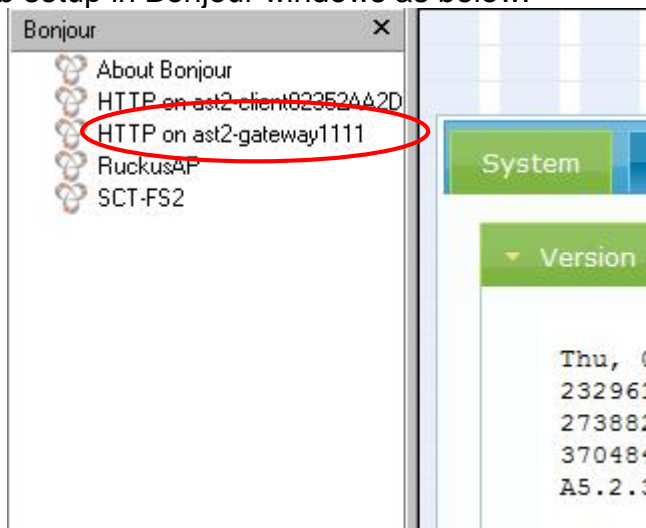

Click Network page you will see the IP address of transmitter/receiver



System Menu:

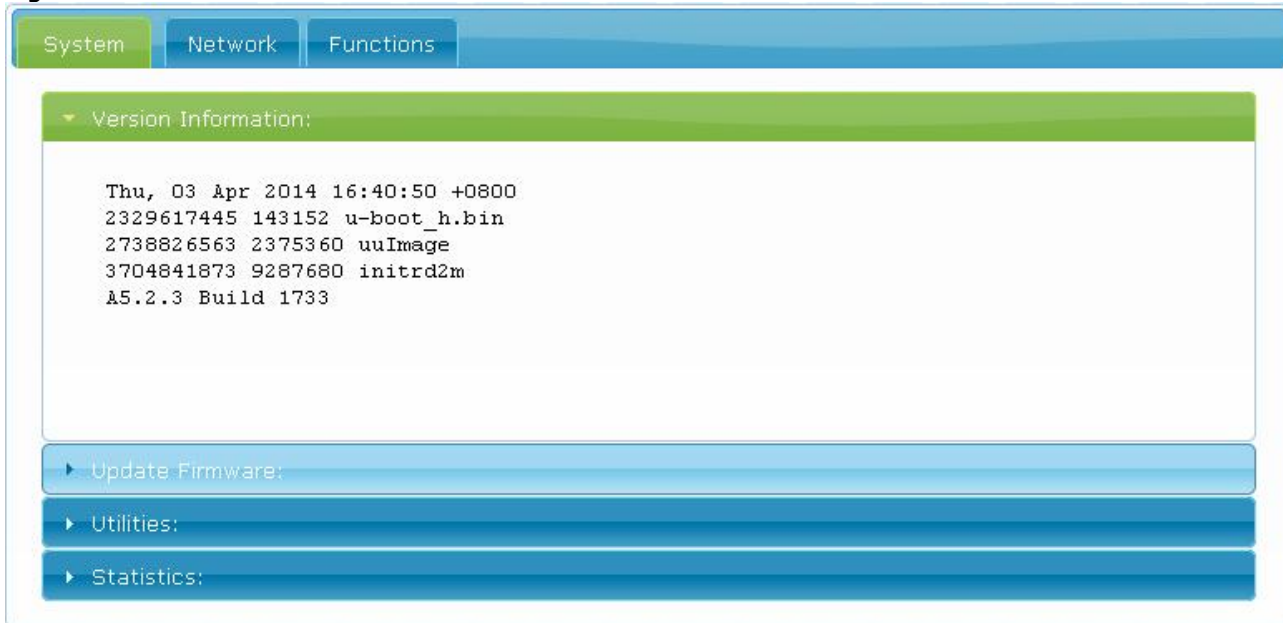

I	Version Information	Firmware version information
I	Update Firmware	Update system firmware
I	Utilities	System tools
	n Factory Default	Set system to factory default
	n Reboot	Reboot system
	n Default EDID	Set EDID to default
	n Console API Command	Run Console API command
I	Statistics	System status

Channel expansion:

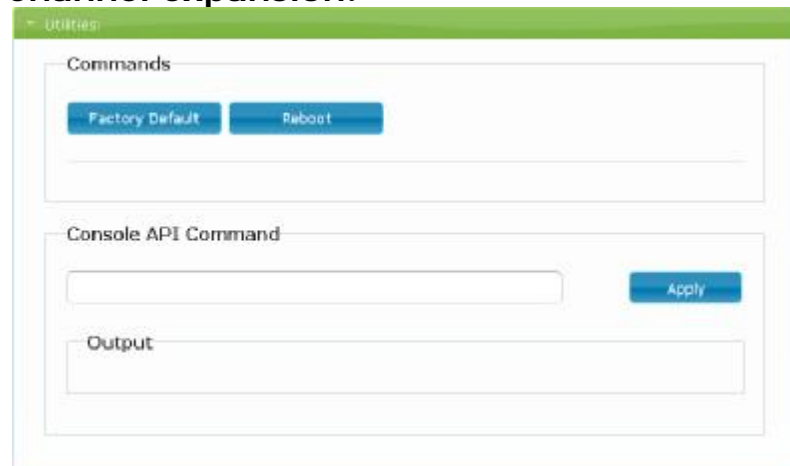

To use channel expansion function (CH.0 ~ CH.99) , please use **DEVICE MANAGER** program which included in package for quick setting, or **copy** and **paste** below command in bold at **System -> Utilities -> Console API Command** to set the transmitter:

Step 1, disable channel setting from rotary switch:

astparam s hostnamebydipswitch n ; astparam s reset_ch_on_boot n

After copy and paste press [Apply] button (notice: do not use **Enter** key)

Set up once only unless you run Factory Default

Step 2, set channel of transmitter:

ast_send_event -1 e_stop_link ; astparam s multicast_ip MULTICAST_IP ; astparam s hostname_id HOSTNAME_ID ; ast_send_event -1 e_chg_hostname ; astparam save ; ast_send_event -1 e_reconnect

After copy and paste press [Apply] button (notice: do not use **Enter** key)

Value of MULTICAST_IP and HOSTNAME_ID as below table:

CHANNEL	MULTICAST IP	HOSTNAME_ID	CHANNEL	MULTICAST IP	HOSTNAME_ID
0	225.0.101.111	1111	50	225.0.131.011	31011
1	225.0.100.111	0111	51	225.0.130.011	30011
2	225.0.101.011	1011	52	225.0.131.101	31101
3	225.0.100.011	0011	53	225.0.130.101	30101
4	225.0.101.101	1101	54	225.0.131.001	31001
5	225.0.100.101	0101	55	225.0.130.001	30001
6	225.0.101.001	1001	56	225.0.131.110	31110
7	225.0.100.001	0001	57	225.0.130.110	30110
8	225.0.101.110	1110	58	225.0.131.010	31010
9	225.0.100.110	0110	59	225.0.130.010	30010
10	225.0.101.010	1010	60	225.0.131.100	31100
11	225.0.100.010	0010	61	225.0.130.100	30100
12	225.0.101.100	1100	62	225.0.131.000	31000
13	225.0.100.100	0100	63	225.0.130.000	30000
14	225.0.101.000	1000	64	225.0.141.111	41111
15	225.0.100.000	0000	65	225.0.140.111	40111
16	225.0.111.111	11111	66	225.0.141.011	41011
17	225.0.110.111	10111	67	225.0.140.011	40011
18	225.0.111.011	11011	68	225.0.141.101	41101
19	225.0.110.011	10011	69	225.0.140.101	40101
20	225.0.111.101	11101	70	225.0.141.001	41001
21	225.0.110.101	10101	71	225.0.140.001	40001
22	225.0.111.001	11001	72	225.0.141.110	41110
23	225.0.110.001	10001	73	225.0.140.110	40110
24	225.0.111.110	11110	74	225.0.141.010	41010
25	225.0.110.110	10110	75	225.0.140.010	40010
26	225.0.111.010	11010	76	225.0.141.100	41100
27	225.0.110.010	10010	77	225.0.140.100	40100
28	225.0.111.100	11100	78	225.0.141.000	41000
29	225.0.110.100	10100	79	225.0.140.000	40000
30	225.0.111.000	11000	80	225.0.151.111	51111
31	225.0.110.000	10000	81	225.0.150.111	50111
32	225.0.121.111	21111	82	225.0.151.011	51011
33	225.0.120.111	20111	83	225.0.150.011	50011
34	225.0.121.011	21011	84	225.0.151.101	51101
35	225.0.120.011	20011	85	225.0.150.101	50101
36	225.0.121.101	21101	86	225.0.151.001	51001
37	225.0.120.101	20101	87	225.0.150.001	50001
38	225.0.121.001	21001	88	225.0.151.110	51110
39	225.0.120.001	20001	89	225.0.150.110	50110
40	225.0.121.110	21110	90	225.0.151.010	51010
41	225.0.120.110	20110	91	225.0.150.010	50010
42	225.0.121.010	21010	92	225.0.151.100	51100
43	225.0.120.010	20010	93	225.0.150.100	50100
44	225.0.121.100	21100	94	225.0.151.000	51000
45	225.0.120.100	20100	95	225.0.150.000	50000
46	225.0.121.000	21000	96	225.0.161.111	61111
47	225.0.120.000	20000	97	225.0.160.111	60111
48	225.0.131.111	31111	98	225.0.161.011	61011
49	225.0.130.111	30111	99	225.0.160.011	60011
CHANNEL	MULTICAST IP	HOSTNAME_ID	CHANNEL	MULTICAST IP	HOSTNAME_ID

Example:

Set transmitter to CH.8:

```
ast_send_event -1 e_stop_link ; astparam s multicast_ip 225.0.101.110 ; astparam s hostname_id 1110 ; ast_send_event -1 e_chg_hostname ; astparam save ; ast_send_event -1 e_reconnect
```

Set transmitter to CH.63 :

```
ast_send_event -1 e_stop_link ; astparam s multicast_ip 225.0.130.000 ; astparam s hostname_id 30000 ; ast_send_event -1 e_chg_hostname ; astparam save ; ast_send_event -1 e_reconnect
```

To disable channel expansion please click [Factory Default] button on web, channel setting will back to 0 ~ F total 16 channels by rotary switch

Network Menu:

The screenshot shows a web interface with a top navigation bar containing 'System', 'Network', and 'Functions' tabs. The 'Network' tab is active. Below the tabs, there are two main sections: 'IP Setup' and 'Casting Mode'. In the 'IP Setup' section, 'IP Mode' is set to 'Auto IP'. Below this are three input fields: 'IP Address' (169.254.1.71), 'Subnet Mask' (255.255.0.0), and 'Default Gateway' (169.254.0.254). An 'Apply' button is located at the bottom right of this section. The 'Casting Mode' section has two radio buttons: 'Multicast' (selected) and 'Unicast'. Below these is a checked checkbox labeled 'Auto select USB operation mode per casting mode (recommended)'. An 'Apply' button is also present at the bottom right of this section.

IP Setup:

- I IP Mode could be Auto IP, DHCP, Static three mode, default is Auto IP
For mass deploying please use static or DHCP mode.
- I Casting Mode : could be Multicast, Unicast mode, default is Multicast ,
When using Multicast mode, please check the “Auto select USB operation mode per casting mode” box

Functions Menu:

Video over IP

Enable Video over IP

Apply

For transmitter:

Video over IP:

This function setup the video signals send from network, default is checked.

Please note it will turn off HDMI output of receivers in same channel if this function be disabled, only analog audio output

Video over IP

Enable Video over IP

Copy EDID from this Video Output (Default disabled under multicast mode)

Apply

For Receiver:

Video over IP:

This function setup the video signals send from network, default is checked.

Please note it will turn off HDMI output of receiver if this function be disabled, only analog audio output

Copy EDID from this Video Output:

Check this box will auto copy EDID from the TV connected to receiver when receiver booting, default is not checked.

In multiple connections transmitter will use default EDID 1080p with 2 channel audio, to prevent EDID conflict recommend check this box in Unicast mode only.

USB over IP

Enable USB over IP

Operation Mode:

- Auto select mode (Recommended, choose per network casting mode)
- Active on link (Unicast network's default mode)
- Active per request (Multicast network's default mode)

USB over IP Setup: (not available for HE05BT/HE05BR/HE05BER)
 This function setup the USB signals send from network, default is checked.

Operation Mode:
 USB device operation setting, default is "Auto select mode"
 In Unicast mode recommend set to "Active on link".
 In Multicast mode recommend set to "Active per request".

Serial over IP

Enable Serial over IP

Operation Mode:

- Type 1 (Need extra control instruction. For advanced usage.)
- Type 2 (Recommended. Dumb redirection.)
- Type 1 guest mode
- Type 2 guest mode

Baudrate Setting for Type 2:

Baudrate:

Data bits:

Parity:

Stop bits:

Serial over IP :
 This function setup Serial (RS232) signal sends from network
 I Operation Mode:
 Default is "Type 2 (Recommended. Dumb redirection.)"
 I Baudrate Setting for Type 2 : **default is 115200, 8, None, 1**

Package:**HE05BT Package Include:**

Transmitter x 1

IR emitter cable x 1

DC 5V 2Amp power adapter x 1

Software CD x1

HKM01BT / DKM01BT / VKM03BT Package Include:

Transmitter x 1

USB A to B cable x 1

IR emitter cable x 1

DC 5V 2Amp power adapter x 1

Software CD x1

HE05BER Package Include:

Receiver x 1

IR receiver cable x 1

IR remote control x1

DC 5V 2Amp power adapter x 1

HE05BR / HKM01BR / VDKM01BR Package Include:

Receiver x 1

IR emitter cable x 1

IR remote control x1

DC 5V 2Amp power adapter x 1

Specification:

ITEM NO.	HE05BT	HKM01BT	DKM01BT	VKM03BT
Support Resolution	480i / 480p / 720p / 1080i / 1080p @ 24Hz、25Hz、30Hz、50Hz、60Hz			
Transmission Distance	CAT.5e : 150M / CAT.6 : 180M (Max)			
USB Connector	X	USB Type B x 1		
RS232 Connector	DB9 (Female) x 1			
Video Input Connector	HDMI type A x 1		DVI-I x 1 (29 Pin) Digital Only	15-pin Mini D-sub
Video Loop Output Connector	HDMI type A x 1		DVI-I x 1 (29 Pin) Digital Only	15-pin Mini D-sub
Link Connector	RJ45 x 1			
Audio Connector	3.5 mm Phone Jack x 2 (10KΩ / 1Vpp)			
IR Receiver (Internal)	30-60Khz / ±45° / 5M			
IR Emitter (External)	3.5mm Stereo Phone Jack			
Power Supply	DC 5V 2A			
Power Consumption	750mA (Typical) / 1000mA (Max)			
Temperature	Operation: 0 to 55°C, Storage: -20 TO 85°C, Humidity: up to 95%			
Dimensions mm	125x140x30	125x140x30	167x105.5x40	167x105.5x40
Weight g	380	380	470	460

ITEM NO.	HE05BER	HE05BR	HKM01BR	VDKM01BR
Support Resolution	480i / 480p / 720p / 1080i / 1080p @ 24Hz、25Hz、30Hz、50Hz、60Hz			
Transmission Distance	CAT.5e : 150M / CAT.6 : 180M (Max)			
USB Connector	X		USB Type A x 4	
RS232 Connector	X	DB9 (Male) x 1		
Video Output Connector	HDMI Type A x 1			DVI-I x 1 (29 Pin) Digital Only / 15-pin Mini D-sub
Link Connector	RJ45 x 1			
Audio Connector	3.5 mm Phone Jack x 2 (10KΩ / 1Vpp)			
IR Receiver (Internal)	38Khz / ±45° / 5M	30-60Khz / ±45° / 5M		
IR Emitter (External)	X	3.5mm Stereo Phone Jack		
IR Receiver (External)	3.5mm Stereo Phone Jack	X		
Power Supply	DC 5V 2A			
Power Consumption	750mA (Typical) / 1000mA (Max) Without USB Power Consumption			
Temperature	Operation: 0 to 55°C, Storage: -20 TO 85°C, Humidity: up to 95%			
Dimensions mm	88x130x30	88x130x30	125x140x30	167x105.5x40
Weight g	260	270	390	480

RoHS   

Rev. A1 V2.52.161102